



PRODUCTS INC.
WATERTOWN WI

FOR SENSOR GUIDE INSERT: SGI-6-875-1.5
FOR SENSORS: SBP-B-4-20-12 (3/16" DIA 12"/24" LONG)

MM-1510-B-1-8-SPRING-PROBE-TYPE-B

PART NO.

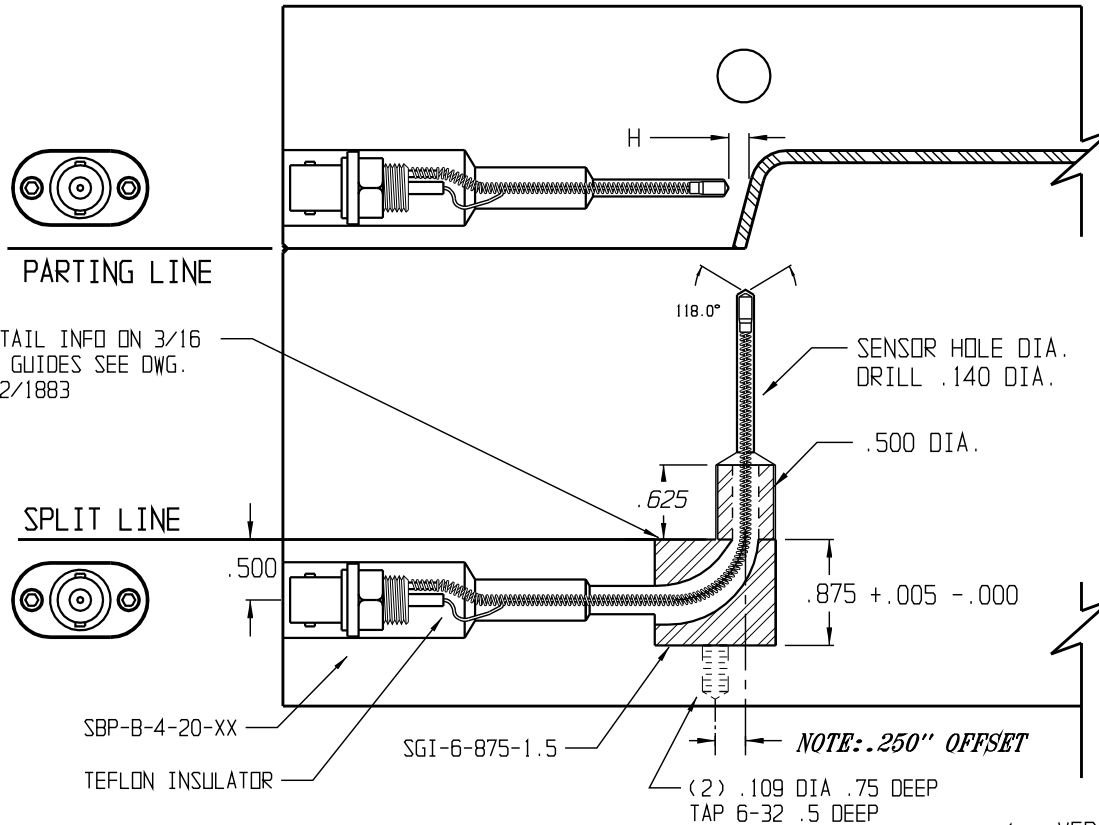

PROBE DISTANCE H

POSITION SENSOR APPROX IN CENTER OF PART
POSITION SENSOR WALL THICKNESS
AWAY FROM MOLDING SURFACE
MIN .100 ON THIN WALL PARTS
= TO WALL THICKNESS
MAX .500 ON THICK WALL PARTS

MACHINING DIMENSIONS

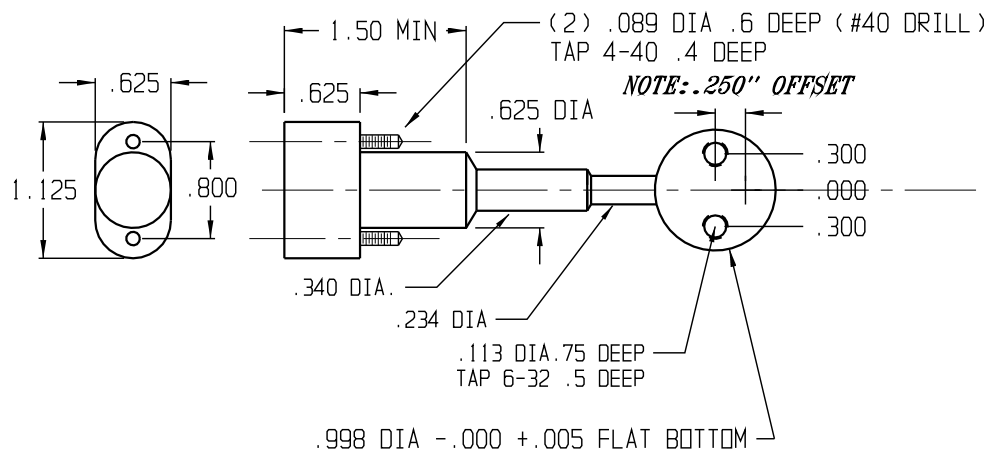

INSTALLATION

- 1 VERIFY POCKET AND HOLE DIMENSIONS. REMOVE BURRS AND SHARP CORNERS CHECK DIMENSIONS.
- 2 SCREW IN ADAPTOR SLEEVE
- 3 INSERT SENSOR. MAKE SURE IT'S PROPERLY SEATED AT TIP CHECK WITH PRUSSIAN BLUE
- 4 CUT OFF SPRING APPROX. 10% LONGER TO COMPRESS SENSOR. AVOID DAMAGE TO CENTER (SIGNAL) WIRE
- 5 EXIT WIRE THRU SIDE OF SPRING APPROX. 10 TURNS FROM END. CUT AND STRIP WIRE
- 6 SLIP INSULATOR SLEEVE ON WIRE AND SOLDER TO CENTER TAB
- 7 SOLDER SPRING TO OUTSIDE TERMINAL WITH ACID SOLDER CLEAN WITH WATER TO NEUTRALIZE THE ACID FLUX TO PREVENT CORROSION OF TERMINALS
- 8 APPLY HEAT TRANSFER COMPOUND TO PROBE TIP AND INSTALL
- 9 TO TEST PROBE CONNECT OHM METER TO CENTER AND OUTER CASE RESISTANCE SHOULD READ 20K OHM AT 77 DEG. F RESISTANCE READING WILL BE LESS AT HIGHER TEMPERATURE

FOR CAD INFO. ON 1/8" AND 3/16" SPRING-PROBE - SEE MM-1522

1/8" "B" SPRING BEAD PROBE AND SENSOR GUIDE INSTALLATION